

RF-2400-NANO

High-performance low-power 2.4GHz RF Module Specifications

12*12mm Nano size , onboard antenna , compatible with all RF-2410x/RF-2400 series

1、 Introduction

RF-2400-NANO is a highly integrated RF transmit/receive modules. The module package the Beken BK2421 chip and its peripheral circuit, makes the SPI port communicate with the MCU directly without any additional external circuit, and reduce product development costs. It has the excellent RF performance in 2.4GHz frequency band, and significant anti-interference ability, low power consumption, NANO size. It can achieve high-speed wireless transmission (up to 2Mbps) with ultra-low power consumption. The receiver's normal operating current is 17mA, transmitter with output power of 0dBm current 17mA, power-down mode current 3uA. It integrates a jamming detection feature can be set by software, can switch to the channel to continue communication without interference.

RF-2400-NANO has the same performance with RF-2400 series module, but the size is smaller, more suitable for mass production and application in all kinds of products with smaller size, such as wristwatch. RF-2400-NANO also sell at a good price if batch purchase, high cost-performance ratio.

2、 Features

- Based on the RF-2400 series models: RF-2400W、 RF-2400P、 RF-2400-V03
- Operation band: 2400-2483.5 MHz ISM band
- Transfer Rate: 1Mbps or 2Mbps
- Programmable output power: (-10dBm, -5dBm, 0dBm, 5 dBm)
- valid data length of Receive/transmit: 1 to 32 bytes
- 6 data pipes for 1:6 star networks
- power supply 1.9V ~ 3.6V
- SPI interface with maximum 8MHz clock
- adopt GFSK modulation, significantly improves the sensitivity of the chip
- the transmission mode consumes 17mA at 0 dBm
- the receive mode consumes 17mA at 1Mbps data transfer rate
- current consumption of 3uA in POWERDOWN mode
- current consumption of 50uA in standby-I mode
- open transmission distance of about 20-50 meters (for reference only)
- The module has many advantage like low cost, stable performance, portability, abundant supply and high cost performance.
- INHAOS will provide a full range of after-sales technical services to help customers to add 2.4GHz wireless communication to product.
- 12x12mm, super miniature size, on-board antenna, application simply.
- Can be configured with external higher gain antenna, obtain better communication performance.

3、 Physical picture of RF-2400 module (Size 12x12mm)



4、 Applications

- Wireless Access System
- Fire & Security Systems
- Remote control
- Intelligent Toys
- Telemetry
- Car alarm
- Industrial Sensors
- Wireless Data Communication
- Intelligent sports equipment
- wireless mouse, keyboard, game joystick

5、RF-2400 Module Pin Information

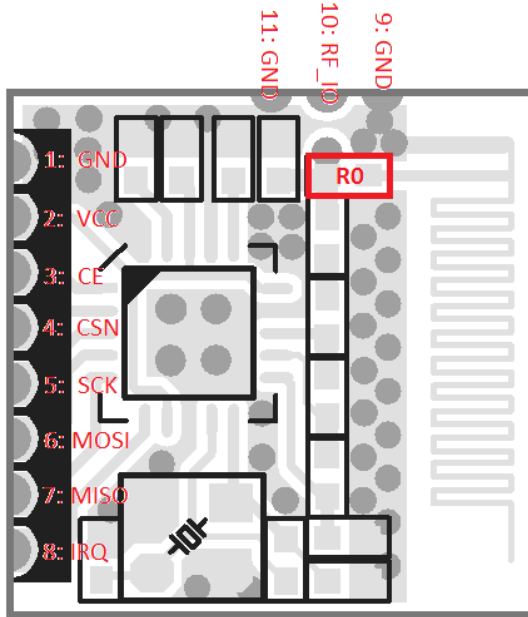

RF-2400-NANO Pin Information

NO.	Name	Functional Description
1	GND	Ground (0V)
2	VCC	Power (1.9V~3.6V)
3	CE	Chip enable , active RX/TX mode ,low active
4	CSN	SPI Chip select
5	SCK	SPI Clock
6	MOSI	Master output, slave input
7	MISO	Master input, slave output
8	IRQ	Maskable interrupt pin, Active low
9	GND	Ground (0V)
10	RF_IO	Extend antenna , see chapter 6
11	GND	Ground (0V)

6、Antenna Selection

RF-2400-NANO have a gain of -5dBm small PIFA on-board antenna. This antenna already apply to RF-2410U, and has good performance. The user can also connect with external higher gain antenna to achieve farther communication distance.

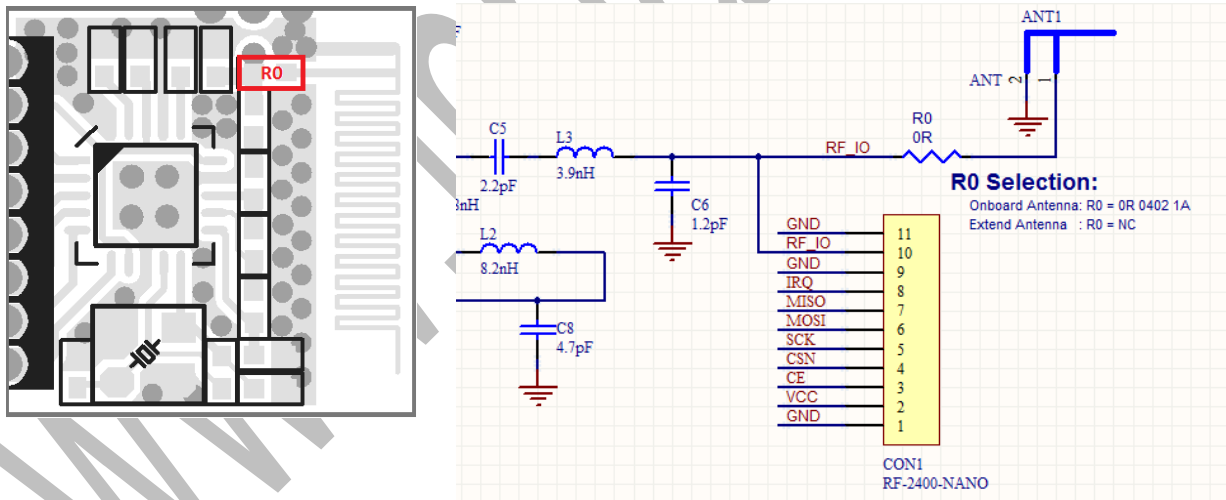

The picture on the left is the PCB figure of RF-2400-NANO, the position of R0 has signed
 The picture on the right is the Schematic of RF-2400-NANO antenna configuration.

The picture shows that when user uses on-board antenna, welding a 0R resistor on R0, under this situation, the RF_IO pin of CON1 should not catch any load, and keep it floating. When user wishes to use an external antenna, should remove R0, connect external antenna to the RF_IO pin of CON1

Attention please: the R0 default in 0 R, use on-board antenna. if users need this product without R0, please inform INHAOS after put the order.

7、Application Notes

INHAOS has done full RF match and debugging on the RF-2400 Series modules to ensure the best performance. Note in application:

7.1: About power supply

The nominal supply voltage of RF-2400 series is 1.9 ~ 3.6V, it is best to provide a stable supply voltage. In order to compatible with 3.3V and 5V MCU system ,we recommend 3.3V power supply. If the power supply has large ripple , we suggest series 10 ohm resistor and 860nF RC filter circuit in the Vcc circuit.

7.2: About the interface level

The modules' IO is compatible with TTL and CMOS . We suggest series 100 ohm resistor to IO port for overload protect.

7.3: About the RF module's position in the machine

In the overall layout, make sure no metal objects 10mm around the antenna. It' s better to right point to RF receiving or transmitting direction. Module should be placed horizontally in the machine.

7.4: About PCB design

In the PCB design, no part or circuit can be placed under the antenna. It must be emptied with no copper.

8、Electric parameter

Name	Parameter	Min	Typical	Max	Unit	Comment
Operating Condition						
VDD	Voltage	1.9	3.0	3.6	V	
TEMP	Temperature	-40	+27	+86	°C	
Digital input Pin						
VIN	High level	0.7VDD		5.25	V	
VIL	Low level	VSS		0.3VDD	V	
Digital output Pin						
VOH	High level(I _{OH} =-0.25mA)	VDD-0.3		VDD	V	
VOL	Low level(I _{OL} =0.25mA)	0		0.3	V	
Normal Condition						
IVDD	Power Down current			3	uA	
IVDD	Standby-I current			50	uA	
IVDD	Standby-II current			400	uA	
Normal RF condition						
FOP	Operating frequency	2400		2527	MHz	

FXTAL	Crystal frequency		16		MHz	
RFSK	Air data rate	1		2	Mbps	
Transmitter						
PRF	Output power	-40	0	5	dBm	
PBW	Modulation 20dB bandwidth(2Mbps)		2.5		MHz	
PBW	Modulation 20dB bandwidth(1Mbps)		1.3		MHz	
PRF1	Out of band emission 2MHz		-20		dBm	
PRF2	Out of band emission 4MHz		-40		dBm	
IVDD	Current at -40dBm output power		11		mA	
IVDD	Current ata-30dBm output power		11		mA	
IVDD	Current ata-30dBm output power		12		mA	
IVDD	Current ata-25dBm output power		13		mA	
IVDD	Current ata-10dBm output power		15		mA	
IVDD	Current ata-0dBm output power		17		mA	
IVDD	Current ata-5dBm output power		23		mA	
Receiver						
IVDD	Current(2Mbps)		18			
IVDD	Current(1Mbps)		17			
Max_Input	1E-3 BER		10			
RXSENS	1E-3 BER sensitivity(2Mbps)		-85			
RXSENS	1E-3 BER sensitivity(1Mbps)		-88			
C/ICO	Co-channel C/I(2Mbps)		4			
C/I1ST	ACS C/I 2MHz(2Mbps)		-5			
C/I2ND	ACS C/I 4MHz(2Mbps)		-20			
C/I3RD	ACS C/I 6MHz(2Mbps)		-25			
C/ICO	Co-channel C/I(1Mbps)		4			
C/I1ST	ACS C/I1MHz(1Mbps)		4			
C/I2ND	ACS C/I 2MHz(1Mbps)		-18			
C/I3RD	ACS C/I 3MHz(1Mbps)		-19			

9、Schematic

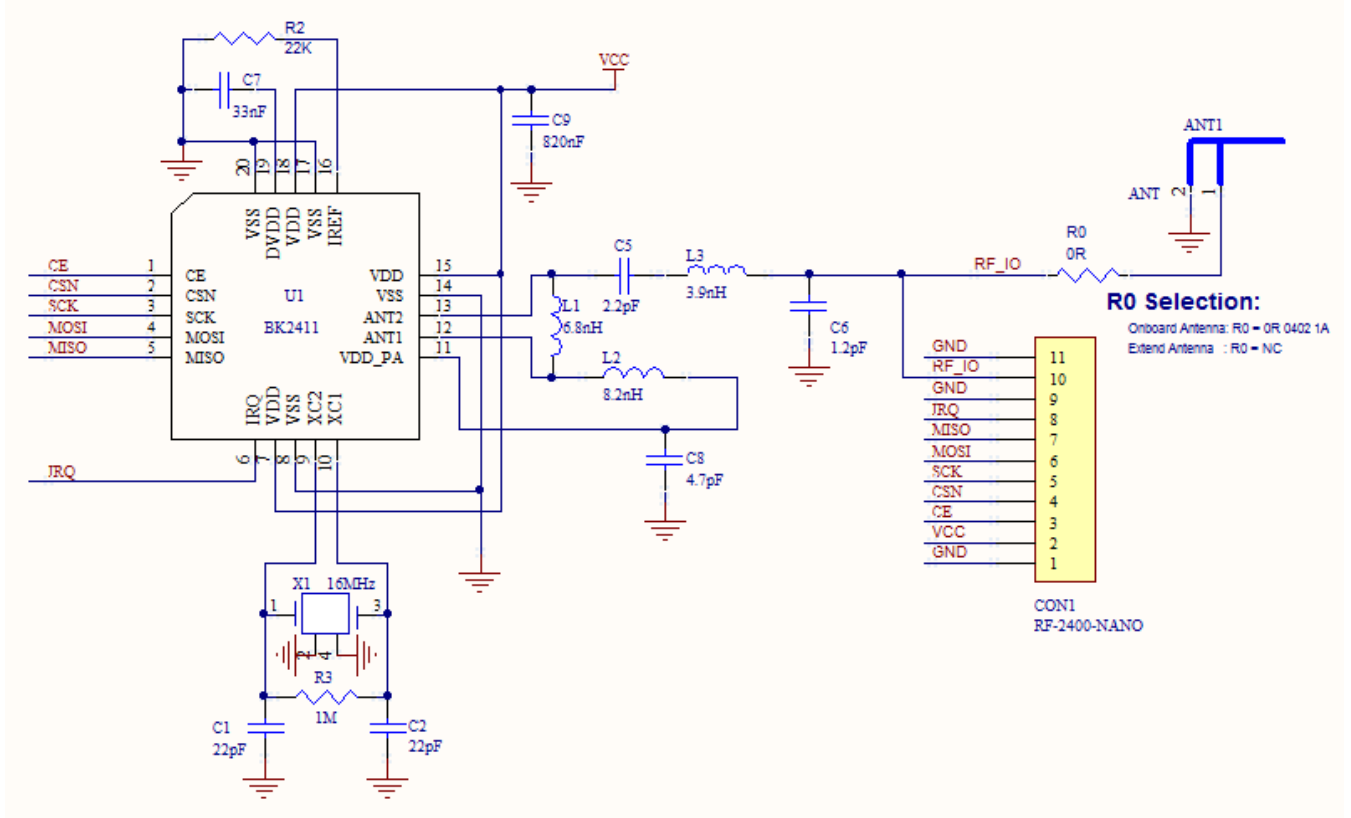

10、RF-2400P Mechanical Dimensions (Unit: mm)

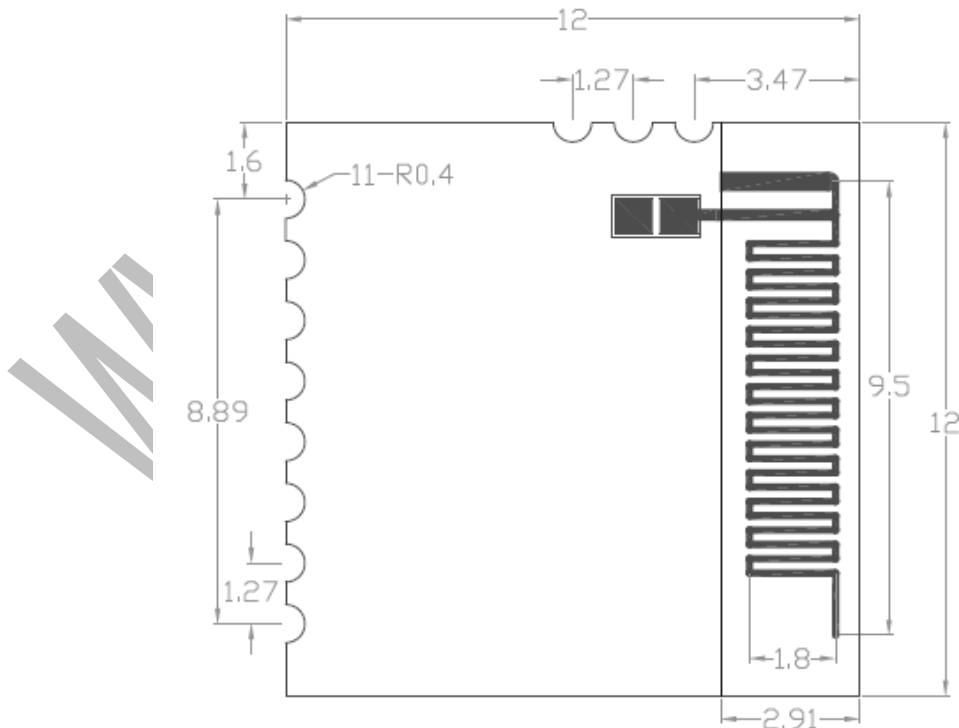

RF-2400-NANO Mechanical Dimensions

11、 RF-2400 Module Application

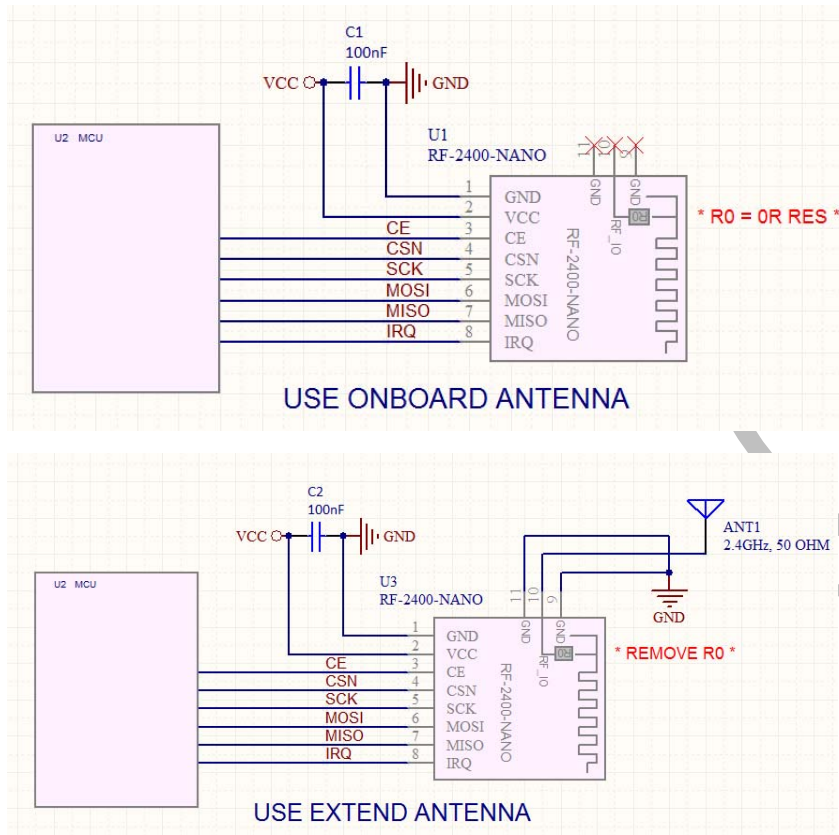

12、 Reference Documents

- 1) RF-2400 Series Operations Guide -C51
- 2) RF-2400 Series Operations Guide -avr
- 3) nRF24L01_Product_Specification_v2_0
- 4) BK2401_BK2421Hardware Reference Designv3.0
- 5) RF-2400 Series Datasheet V1.1

15、 Revision History

Version	Date	Author	Description
V10	2012-4-23	Momo Wen	

www.inhaos.com

Declare

Due to technical limitations and the reader's understanding , this document is for reference only. Our company makes no legal commitment or guarantee of the document. If you have any doubt, please feel free to contact our company or authorized service provider, thank you! (The source code of the example can be download form www.inhaos.com.See the website for more technical support

Copyright

All the devices mentioned in this document are all cited from the information of the company copyright reserved. The rights to modify and distribute belong to the company, we do not make any guarantees of the information. When in application, please confirm the information updated through the appropriate channels ,and adjust accordingly.

About Us

INHAOS is a high-tech private limited company combined with electronic products, telecommunications equipment, computer peripheral equipment development and sales. Aiming to promote domestic IT technological progress, we develop a series of embedded product development kit. This kit comes from large quantities of commercial product. The user can use it directly for design and verification, also can quickly convert the design to production and collect new product design ideas .

We also can undertake the following services:

- Electronic product design
- Brand components acting
- Embedded development kit, Circuit module

Contact Us: <http://www.inhaos.com/about.php?aID=7>